

ZYON  
GRAND

THE WAY OF IKEBANA IS  
THE WAY OF TRANSFORMATION

TURNING THE ORDINARY  
INTO THE EXTRAORDINARY



ELEVATING LIFE INTO POETRY  
DISTILLING BEAUTY TO ITS ESSENCE

# ZYON GRAND



## INSPIRED BY THE ART OF IKEBANA

Soaring 62 storeys high, the iconic twin-tower residence of ZYON GRAND is set to transform into a new icon near Singapore's coveted River Valley precinct. Petaline eaves wrap around the towers, blooming at the crown. Elegant and evocative, like floral centrepieces in the sky.

# AN ICON BEYOND COMPARE

Designed by world-renowned Japanese architecture firm Nikken Sekkei in collaboration with ADDP Architects LLP, ZYON GRAND is an unrivalled integrated development crowned by two stunning residential towers infused with Japanese sensibility and refinement.

Amongst the tallest towers in the district, they rise as iconic beacons on Singapore's skyline, offering unparalleled views of Marina Bay and Sentosa. Like a flower that transforms – and in doing so, transforms its surroundings – ZYON GRAND transcends the ordinary, elevating urban living into an extraordinary experience.

A defining vision of Nikken Sekkei, ZYON GRAND is the latest in a portfolio of iconic projects around the world, which includes the Singapore Rail Corridor Master Plan, Tokyo Skytree (Japan) and One Za'abeel (Dubai).



# AN UNRIVALLED INTEGRATED DEVELOPMENT

The only integrated development directly linked to Havelock MRT station, ZYON GRAND is a truly unrivalled residence that brings together luxury homes, restaurants (F&B) and supermarket, an early childhood development centre, and Singapore's first long-stay serviced apartments. Jointly developed by CDL and Mitsui Fudosan, it is set to become the district's most definitive landmark. Prestige, convenience, connectivity, and liveability – ZYON GRAND has it all.

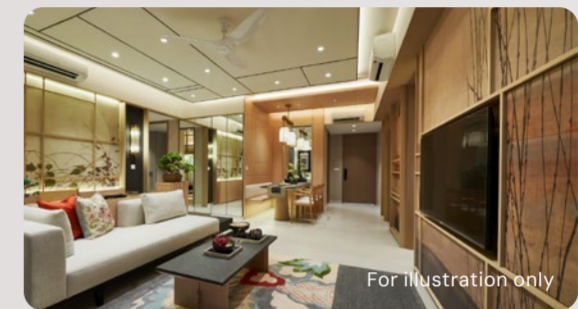

For illustration only

LUXURY RESIDENCES



For illustration only

HAVELOCK MRT STATION

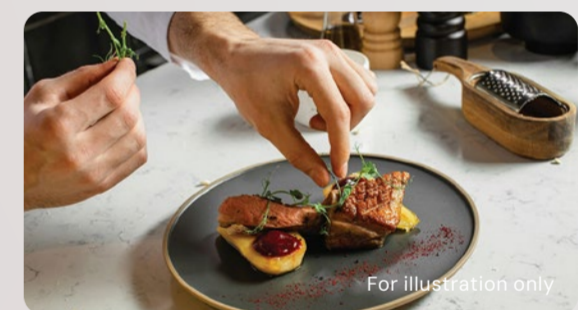

For illustration only

RESTAURANTS (F&B) AND SUPERMARKET



For illustration only

EARLY CHILDHOOD DEVELOPMENT CENTRE

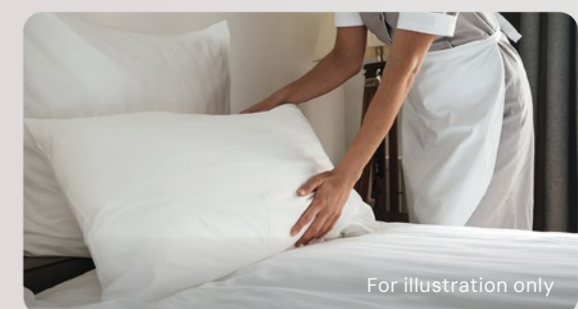

For illustration only

LONG-STAY SERVICED APARTMENTS

LONG-STAY SERVICED APARTMENTS

LUXURY RESIDENCES

HAVELOCK MRT STATION | RESTAURANTS (F&B) AND SUPERMARKET  
EARLY CHILDHOOD DEVELOPMENT CENTRE

# UNPARALLELED VIEWS OF MARINA BAY AND SENTOSA

Taking prime position in a prestigious enclave undergoing revitalisation, ZYON GRAND stands at the heart of what is fast becoming the city's new focal point. Located near the River Valley precinct, ZYON GRAND offers a life that is more vibrant, more liveable, and more lovable – ideal for families and the discerning alike.

With character and charm, and now even better connected by the Thomson–East Coast MRT Line, this locale opens up new possibilities for growth. Just a stone's throw from the tranquillity of the Singapore River, it is mere minutes by train – two stops to Orchard, three to Shenton Way, four to Marina Bay.

Here, the city unfolds before you. From selected residences, enjoy captivating views – some overlooking the downtown skyline, others framing Marina Bay Sands or Sentosa beyond. A home in every sense, with the city's best always within reach.





*YOUR HOME ABOVE  
YOUR WORLD APART*

# SEAMLESS CONNECTIONS TO EVERYWHERE YOU WANT TO GO

## ARTS & CULTURE

ArtScience Museum  
 Asian Civilisations Museum  
 Esplanade Theatres on the Bay  
 National Gallery Singapore  
 National Museum of Singapore

## RETAIL & DINING

Clarke Quay  
 Great World  
 Marina Bay Sands  
 Orchard Road Shopping District  
 Robertson Quay  
 Tiong Bahru Food Centre  
 Valley Point Shopping Centre  
 Zion Riverside Food Centre

## LEARNING

Brighton Montessori River Valley  
 Crescent Girls' School  
 Nanyang Academy of Fine Arts (NAFA)  
 River Valley Primary School  
 School of the Arts (SOTA)  
 Singapore Management University (SMU)

## WORK

Central Business District (CBD)  
 Marina Bay Financial Centre

## PARKS & RECREATION

Alexandra Park Connector  
 Esplanade Park  
 Fort Canning Park  
 Istana Park  
 Kim Seng Park  
 Mount Emily Park  
 Pearl's Hill City Park

## CONNECT

Great World MRT Station (TEL)  
 Havelock MRT Station (TEL)  
 Orchard MRT Station (TEL/NSL)  
 Outram Park MRT Station (TEL/EWL/NEL)  
 Raffles Place MRT Station (NSL/EWL)

## LEGEND

--- East-West Line (EWL)    --- Circle Line (CCL)  
 --- North-South Line (NSL)    --- Downtown Line (DTL)  
 --- North East Line (NEL)    --- Thomson-East Coast Line (TEL)

The location map is taken from [www.onemap.gov.sg](http://www.onemap.gov.sg) as at July 2025. While reasonable care has been taken in the preparation of the location map and the depiction of amenities (including the location(s) of the school(s) shown in the location map) surrounding the housing project are purely to provide general information on the housing project to be constructed and the amenities surrounding the housing project, which are subject to change without notice as determined by the relevant authorities or otherwise. The location map is not to be relied on as if it contains any statements or representations of fact or warranties (whether expressly or impliedly) by the Developer, and intending purchasers should, if they wish, seek confirmation from the relevant authorities on the accuracy, reliability or completeness of the information herein. For home-school distance and school admission criteria, please obtain the relevant authorities' confirmation.



# JUST STEPS AWAY, THE CITY'S HEART BEATS

Step into a neighbourhood filled with sophisticated charm and gentle rhythm. From artisanal cafés and glitzy shops to leafy trails and hilltop strolls, ZYON GRAND places you at the heart of it all – where everything you love is all around.



**ORCHARD ROAD SHOPPING DISTRICT**  
World-class shopping street, a mere two train stops away



**TIONG BAHRU**  
Discover charming heritage shophouses, a hawker centre, and cafés nearby



**GREAT WORLD**  
Your choice of dining, retail, and everyday essentials nearby



**HAVELOCK MRT STATION**  
Directly below where you live, the entire city is within easy reach



**KIM SENG PARK**  
Leafy retreat by the river, perfect for leisurely family strolls

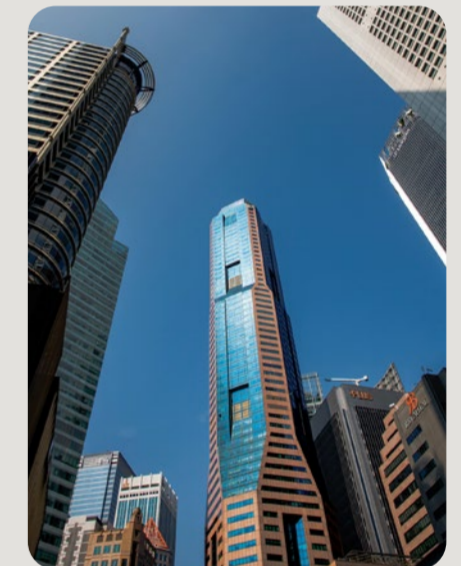

**CENTRAL BUSINESS DISTRICT**  
Singapore's financial and commercial hub, three train stops away



**MARINA BAY SANDS**  
Shop, dine, and experience world-class entertainment at Singapore's iconic integrated resort



**ROBERTSON QUAY**  
Experience vibrant quayside lifestyle, where gastronomic delights and nightlife await



**RIVER VALLEY PRIMARY SCHOOL**  
Sought-after school located nearby

STEP WITHIN

AND DISCOVER  
*A PRIVATE OASIS*





WELLNESS OASIS  
Artist's Impression

# A HOME THAT AWAKENS A HIGHER SENSE OF BEING

Inspired by the flowing forms of canyons and rivers, the lush landscape at ZYON GRAND weaves nature seamlessly into your home. Like ikebana, every element is choreographed to evoke poetry and elegance. Undulating decks and meandering pools connect quiet and social zones, framing tranquil spaces to commune with nature. From the lower to the upper deck, this living oasis invites you to pause, reflect, and return to what is truly essential.



GRAND LAWN

Artist's impression

B1 / LOWER 1<sup>ST</sup> STOREY

## EVERYDAY ESSENTIALS, RIGHT BELOW



B1 / LOWER 1<sup>ST</sup> STOREY

- 1 Residential Carpark Entry
- 2 Residential Carpark Exit
- 3 Guardhouse
- 4 Arrival Court for Residential
- 5 Residential Lobby (Blk 3)
- 6 Residential Lobby (Blk 5)
- 7 Arrival Court for Commercial & Serviced Apartments II
- 8 Through-block Link

ANCILLARY

- A Residential Genset
- B Commercial Genset
- C Residential Substation (Basement 3)
- D Commercial Substation (Basement 3)
- E Bin Centre (Basement 3)
- F Ventilation Shaft
- Early Childhood Development Centre (ECDC)
- Supermarket/Restaurants (F&B)

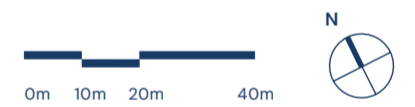

The renderings of the units as shown are for illustrative purposes only. The shading and outline of the unit type only applies to typical units from Level 2 to 21 and Level 23 to 42. The boundary lines of the units set out here are not to be taken as a representation of the actual units. Kindly refer to the approved BP plans for the actual unit outline/boundary lines.



For illustration only

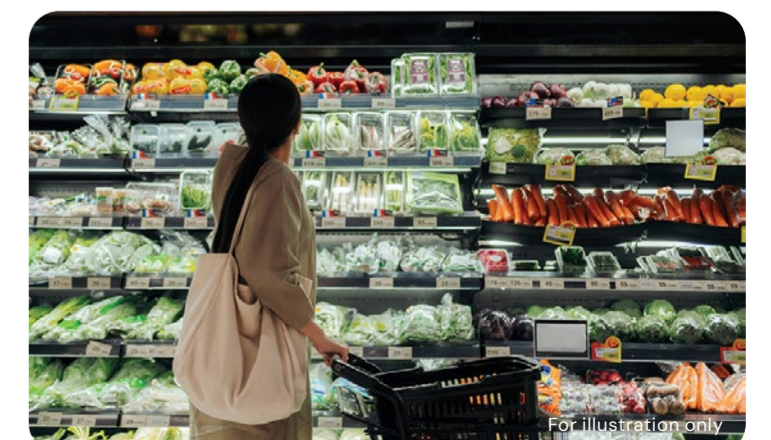

For illustration only

# FACILITIES FOR EVERY LIFESTYLE



The renderings of the units as shown are for illustrative purposes only. The shading and outline of the unit type only applies to typical units from Level 2 to 21 and Level 23 to 42. The boundary lines of the units set out here are not to be taken as a representation of the actual units. Kindly refer to the approved BP plans for the actual unit outline/boundary lines.

### ARRIVAL SANCTUARY

- 1 Grand Pavilion
- 2 Reflective Court
- 3 Arrival Cascades
- 4 Water Reflexology

### SOCIAL HABITAT

- 5 Central Club
- 5A Club Gourmet
- 5B Club Social
- 5C Residential Services Reception
- 6 Tennis/Pickleball Court
- 7 Chill Out Lounge
- 8 Serenity Swing
- 9 Adventure Playground
- 10 Club Culinary
- 11 Play Deck
- 12 Kids Pool
- 13 Pets Play

### RELAXATION LAGOON

- 14 Lagoon Deck
- 15 Bubbling Pool
- 16 Hydro Splash
- 17 Hydro Lounge
- 18 Hydro Spa
- 19 Family Pool
- 20 Family Deck

### WELLNESS OASIS

- 21 Grand Lawn
- 22 Leisure Lawn
- 23 BBQ Pavilion
- 24 Gourmet Pavilion
- 25 50m Lap Pool
- 26 Aqua Lounge
- 27 Aqua Bed
- 28 Pool Deck
- 29 Aqua Pavilion
- 30 Waterfall Deck
- 31 Waterfall Cove
- 32 Waterfall Lounge
- 33 Fitness Suite
- 34 Yoga Studio
- 35 Media Room
- 36 Games Studio
- 37 Changing Room (with Steam Room)

### LEGEND

- 1-Bedroom + Study
- 2-Bedroom
- 2-Bedroom Premium
- 2-Bedroom Premium + Study
- 3-Bedroom
- 3-Bedroom Deluxe
- 3-Bedroom Premium + Study
- 4-Bedroom Premium (with Private Lift)
- 4-Bedroom Supreme (with Private Lift)

Water Tank (Roof)

# INTEGRATED FOR UNMATCHED CONVENIENCE

Arrive at an exclusive drop-off reserved solely for residents. As an integrated development directly linked to Havelock MRT station, ZYON GRAND offers unmatched connectivity. Just below the residences, ZYON GALLERIA presents a curated selection of restaurant (F&B) options and a supermarket. An early childhood development centre within the development adds even greater convenience — bringing vibrancy and refinement to daily life, all just steps from your door.



ZYON GALLERIA



ARRIVAL COURT FOR RESIDENTIAL

# ARRIVAL SANCTUARY

Opening elegantly towards the sky, the Grand Pavilion makes an unforgettable first impression both poetic and sublime, with an elegant sculptural garden cradled by reflective waters. More than an arrival, this is the beginning of a sensorial journey — one that warmly invites you inward, into a world of composure, introspection, and beauty.

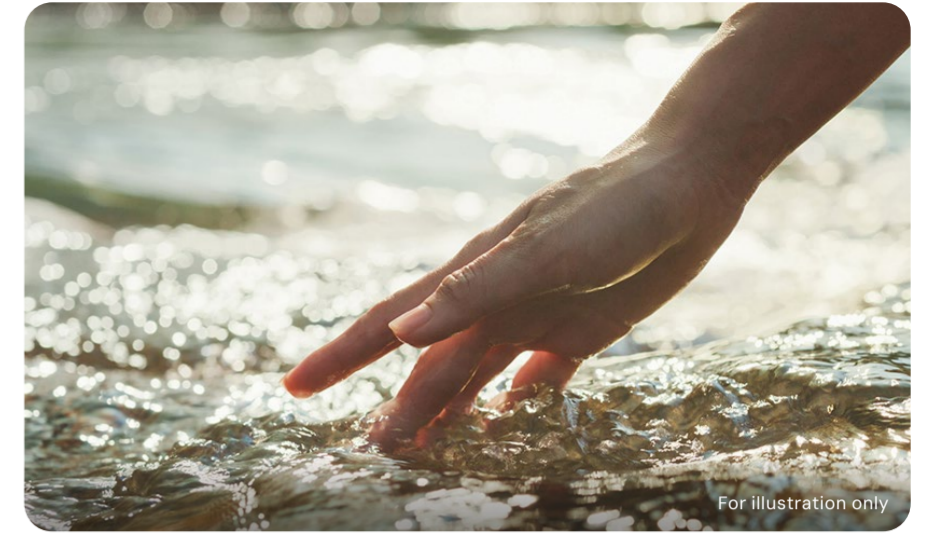

For illustration only



Artist's impression

# SOCIAL HABITAT

From the Grand Pavilion, step into the Social Habitat, where spaces like Club Gourmet and Club Social are created to inspire connection and celebration. Whether hosting an intimate dinner in the fully equipped kitchen or unwinding in the lounge, every moment is crafted for togetherness and joy. Just steps away, the Tennis/Pickleball Court invites recreation and play amidst lush greenery.



CLUB SOCIAL



CLUB CULINARY



CLUB GOURMET

Artist's impression

# RELAXATION LAGOON

The Relaxation Lagoon is surrounded by water for both play and pause. Reminiscent of meandering streams and shaded river islands, this tropical retreat welcomes everyone — whether sharing joyful moments with your little ones in the Family Pool or relaxing with a drink by the water's edge.



For illustration only



Artist's impression

HYDRO SPA



Artist's impression

RELAXATION LAGOON

# WELLNESS OASIS

The Wellness Oasis offers a serene escape devoted to movement and mindfulness. Glide through the 50m Lap Pool, or ease into stillness in the Aqua Lounge. Nearby, the Yoga Studio allows for mindful movement while the Fitness Suite provides a well-equipped space to exercise against a backdrop of greenery.



YOGA STUDIO



FITNESS SUITE



WATERFALL COVE



50M LAP POOL

# HORIZON VISTA

Midway to the sky, Horizon Vista opens up to sweeping views and spectacular sunsets. Breathe in the sweet scent of the Harvest Garden, find quiet clarity at the Meditation Deck, or feel the sensation of each step along the Reflexology Walk. With spaces for outdoor fitness, mindful repose, and contemplative pause, this elevated terrace invites you to linger, look out, and feel renewed.



- 1 Harvest Garden
- 2 Chess Garden
- 3 Reflexology Walk
- 4 Outdoor Fitness
- 5 Meditation Deck

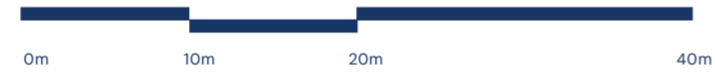

The renderings as shown are for illustrative purposes only. The boundary lines set out here are not to be taken as a representation of the sky terrace floor plan. Kindly refer to the approved BP plans for the actual boundary lines.



# ALTITUDE LOUNGE

The Altitude Lounge unveils an extraordinary expanse of endless sky and palpable calm. From the Sky Lookout and Altitude Deck, enjoy breathtaking views of the city. Here, the world unfolds from a different perspective. Nature feels close, time slows, and the city flourishes beneath you like a living tapestry.



- 1 Skylight Lounge
- 2 Altitude Deck
- 3 Sky Bay
- 4 Sky Lookout
- 5 Altitude Swing

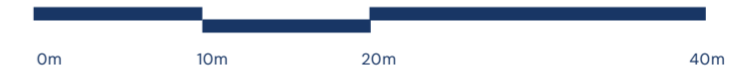

The renderings as shown are for illustrative purposes only. The boundary lines set out here are not to be taken as a representation of the sky terrace floor plan. Kindly refer to the approved BP plans for the actual boundary lines.



A HAVEN OF  
GRACE, RENEWAL,

AND SUBLIME  
TRANQUILLITY





Artist's impression

# LUXURY LIVING, ELEVATED TO PERFECTION

From 1-Bedroom + Study to spacious 5-Bedroom Supreme unit types and two exclusive Penthouses, each home is thoughtfully designed for modern living, with interiors defined by a natural palette and understated sophistication. For 4-Bedroom Premium unit types and above, enjoy the added privilege of a private lift, offering discreet access and elevated privacy.

The living room is appointed with a ceiling fan, its gentle flow bringing grace and comfort to daily life. In the kitchen and bathrooms, thoughtful design meets innovation with an integrated magnetic accessories wall system, a practical provision that allows flexibility to move and arrange the accessories without any installation required. Premium kitchen appliances complete the space with exquisite refinement and seamless functionality.



Well-planned kitchen designed for culinary adventures



Integrated magnetic accessories wall system adapts to every lifestyle



Thoughtfully designed living spaces elevate the everyday



Scan to view integrated magnetic accessories wall system demo

# SPACES MADE FOR REST AND REVERIE

Retreat into your inner sanctuary, designed to soothe the senses and still the mind. In the master bedroom, the wardrobe exudes luxurious elegance, while a warm, natural palette sets the tone for repose.

The same sense of calm extends into the bathroom, where the vanity wall echoes this material serenity. Equipped with branded bathroom fittings and sanitary wares, the bathrooms also feature an integrated magnetic accessories wall system that keeps essentials within effortless reach while maintaining a clean, uncluttered aesthetic. Every element has been thoughtfully composed to transform daily moments into quiet indulgence.



Bathroom with branded fittings



Built-in L-shaped wardrobe in the master bedroom for elegant storage (for 4-Bedroom Premium unit types and above)



Spacious master bedroom for rest and respite



Scan to view Caccaro wardrobe demo

# CONVENIENCE AND PEACE OF MIND FOR EASY LIVING



For illustration only

## PREMIER RESIDENTIAL SERVICES

Elevate your everyday life with seamless assistance from our dedicated team of Residential Hosts. From delivery acceptance to transport and housekeeping arrangements, restaurant reservations and more – luxuriate in a suite of services\* befitting your extraordinary home.

\* Selected services are chargeable. Terms and conditions apply.

## SMART HOMES



For illustration only

Step into a home where technology anticipates your needs. With lighting, air-conditioning, security, and energy use connected through a single mobile app, enjoy effortless control, comfort, and peace of mind, wherever you are.



### SMART HOME GATEWAY

Connects smart appliances, allowing you to remotely control them via the Smart Home App on your mobile device.



### SMART SURVEILLANCE

Enjoy the added security of remote surveillance with a smart IP camera at home.



### SMART AIR CON CONTROLS

Hot day? Turn on the air conditioning remotely and have the home cooled in preparation for your return.



### SMART ENERGY MONITORING

Keep track of your household energy consumption to keep up sustainable habits.



### SMART LIGHTING CONTROLS

Schedule lights to turn on automatically, or check if you have left them on.



### SMART WIFI DOORBELL

Get notified when someone is at the door, so you can see who is paying a visit and communicate with them.



### SMART DIGITAL LOCKSET

Enjoy the convenience of locking or unlocking the door remotely. You can also use PIN, biometrics, key or access card.

## SMART COMMUNITY

Life at ZYON GRAND extends beyond your front door. With a mobile app that simplifies facility bookings, manages visitor access, and streamlines daily conveniences, you can make the most of the development's amenities and enjoy a life of effortless ease.



### SMART BOOKING/PAYMENT

Easily check availability, book and pay for facilities, then check in seamlessly with your access card.



### SMART AUDIO VIDEO TELEPHONY

Receive notifications and grant guests entry upon arrival, via the mobile app.



### SMART INVITE

Pre-register guests and generate QR codes to allow them effortless access to the development.



### KEYLESS LETTERBOX

Collect your mail with easy, secure, keyless access.



### SMART PARCEL

Parcel station offers a secure and convenient package pickup.

Smart Home: The unit will be provided with the following items: a) Smart Home Gateway, b) Smart IP Camera, c) Smart WiFi Doorbell, d) Smart Digital Lockset for Main Door of the Unit, e) Smart Lighting Controls for foyer light, living room light and master bedroom light, f) Smart Air Conditioner Controls and g) Smart Energy Monitoring System (collectively, "SMART Home System"). The make, model, brand, design and technology of the SMART Home System to be supplied and installed in the actual unit may differ from the above illustration and are subject to change. Terms and conditions apply. Buyers shall be required to liaise with the smart home vendor instead of the developer to make all arrangements for the set-up, configuration, subscription and use of the SMART Home System, and for any queries, maintenance and/or upgrade issues with the SMART Home System. Additional items/devices which are not listed above are not included in SMART Home System and may be purchased from the smart home vendor directly and installed at buyers' own costs after the handover of the unit.

# EMBRACING A SUSTAINABLE FUTURE



For illustration only

## GREEN FEATURES

ZYON GRAND has been awarded the **BCA Green Mark 2021 Platinum Super Low Energy** certification, with **Health & Wellbeing, Whole Life Carbon and Maintainability** badges attained. These accolades reflect the thoughtful integration of green features – from energy-efficient design and sustainable materials to smart systems – that together elevate the development's sustainability and liveability.



### ENERGY-EFFICIENT FEATURES

All residential units come with energy-efficient air-conditioning systems.

Energy-efficient lighting design with use of LED lighting and motion sensors at common areas.

Energy-efficient lifts with regenerative drive, VVVF (variable voltage variable frequency) drive and sleep function mode.



### WHOLE LIFE CARBON

Whole Life Carbon looks at the total carbon impact of a building – from construction to daily use.

ZYON GRAND is thoughtfully designed to reduce the carbon impact of construction, showing a strong commitment to a greener future.

This is achieved through smarter design choices, careful selection of materials, and building methods that minimise waste and pollution.

More than half of the total floor area is built using Prefabricated Prefinished Volumetric Construction (PPVC), which improves efficiency and reduces waste.

The use of certified sustainable materials endorsed by the Singapore Green Building Council, ensures proven credibility and environmental responsibility.



### ENERGY-EFFICIENT DESIGN

Building orientation enhances natural ventilation in the common areas and residential units.

Building façade designed to reduce solar heat gain.

Residential units have deep recessed balconies and/or deep horizontal ledges which provide shade for the interiors.

Porous building design allows comfortable airflow throughout the development.



### HEALTH & WELLBEING

Use of environmentally friendly and sustainable materials certified by approved local certification bodies.

Low Volatile Organic Compounds (VOC) paints for all internal walls to ensure healthy indoor air quality.

Landscaped podium and water features reduce urban heat build-up, creating a cooler, more comfortable environment.

Provision of bicycle parking lots to promote green mobility and active lifestyles.

Smart home with smart community system for residents' comfort and convenience.

# SCHEMATIC DIAGRAM

## BLOCK 3, KIM SENG ROAD, S(169558)

UNIT FLOOR	01	02	03	04	05	06
62	PH2 (#62-01)		CD1	BP2s	B1	C1
61	ES1	CP2s	CD1	BP2s	B1	C1
60	ES1	CP2s	CD1	BP2s	B1	C1
59	ES1	CP2s	CD1	BP2s	B1	C1
58	ES1	CP2s	CD1	BP2s	B1	C1
57	ES1	CP2s	CD1	BP2s	B1	C1
56	ES1	CP2s	CD1	BP2s	B1	C1
55	ES1	CP2s	CD1	BP2s	B1	C1
54	ES1	CP2s	CD1	BP2s	B1	C1
53	ES1	CP2s	CD1	BP2s	B1	C1
52	ES1	CP2s	CD1	BP2s	B1	C1
51	ES1	CP2s	CD1	BP2s	B1	C1
50	ES1	CP2s	CD1	BP2s	B1	C1
49	ES1	CP2s	CD1	BP2s	B1	C1
48	ES1	CP2s	CD1	BP2s	B1	C1
47	ES1	CP2s	CD1	BP2s	B1	C1
46	ES1	CP2s	CD1	BP2s	B1	C1
45	ES1	CP2s	CD1	BP2s	B1	C1
44	ES1	CP2s	CD1	BP2s	B1	C1
43	ALTITUDE LOUNGE					
42	DS1	CP2s	CD1	BP2s	B1	C1
41	DS1	CP2s	CD1	BP2s	B1	C1
40	DS1	CP2s	CD1	BP2s	B1	C1
39	DS1	CP2s	CD1	BP2s	B1	C1
38	DS1	CP2s	CD1	BP2s	B1	C1
37	DS1	CP2s	CD1	BP2s	B1	C1
36	DS1	CP2s	CD1	BP2s	B1	C1
35	DS1	CP2s	CD1	BP2s	B1	C1
34	DS1	CP2s	CD1	BP2s	B1	C1
33	DS1	CP2s	CD1	BP2s	B1	C1
32	DS1	CP2s	CD1	BP2s	B1	C1
31	DS1	CP2s	CD1	BP2s	B1	C1
30	DS1	CP2s	CD1	BP2s	B1	C1
29	DS1	CP2s	CD1	BP2s	B1	C1
28	DS1	CP2s	CD1	BP2s	B1	C1
27	DS1	CP2s	CD1	BP2s	B1	C1
26	DS1	CP2s	CD1	BP2s	B1	C1
25	DS1	CP2s	CD1	BP2s	B1	C1
24	DS1	CP2s	CD1	BP2s	B1	C1
23	DS1	CP2s	CD1	BP2s	B1	C1
22	HORIZON VISTA					
21	DS1	CP2s	CD1	BP2s	B1	C1
20	DS1	CP2s	CD1	BP2s	B1	C1
19	DS1	CP2s	CD1	BP2s	B1	C1
18	DS1	CP2s	CD1	BP2s	B1	C1
17	DS1	CP2s	CD1	BP2s	B1	C1
16	DS1	CP2s	CD1	BP2s	B1	C1
15	DS1	CP2s	CD1	BP2s	B1	C1
14	DS1	CP2s	CD1	BP2s	B1	C1
13	DS1	CP2s	CD1	BP2s	B1	C1
12	DS1	CP2s	CD1	BP2s	B1	C1
11	DS1	CP2s	CD1	BP2s	B1	C1
10	DS1	CP2s	CD1	BP2s	B1	C1
9	DS1	CP2s	CD1	BP2s	B1	C1
8	DS1	CP2s	CD1	BP2s	B1	C1
7	DS1	CP2s	CD1	BP2s	B1	C1
6	DS1	CP2s	CD1	BP2s	B1	C1
5	DS1	CP2s	CD1	BP2s	B1	C1
4	DS1	CP2s	CD1	BP2s	B1	C1
3	DS1	CP2s	CD1	BP2s	B1	C1
2	DS1	CP2s	CD1	BP2s	B1	C1
1 <sup>ST</sup> / UPPER 1 <sup>ST</sup>	LANDSCAPE DECK					
B1 / LOWER 1 <sup>ST</sup>	RESIDENTIAL / COMMERCIAL CARPARK   RESTAURANTS (F&B) & SUPERMARKET					
B2	RESIDENTIAL CARPARK					
B3	RESIDENTIAL CARPARK					

## BLOCK 5, KIM SENG ROAD, S(169557)

UNIT FLOOR	07	08	09	10	11	12	UNIT FLOOR
62	PH1 (#62-08)		CD1	BP2s	A1s	BP1	62
61	CP1s	DS2s	CD1	BP2s	A1s	BP1	61
60	CP1s	DS2s	CD1	BP2s	A1s	BP1	60
59	CP1s	DS2s	CD1	BP2s	A1s	BP1	59
58	CP1s	DS2s	CD1	BP2s	A1s	BP1	58
57	CP1s	DS2s	CD1	BP2s	A1s	BP1	57
56	CP1s	DS2s	CD1	BP2s	A1s	BP1	56
55	CP1s	DS2s	CD1	BP2s	A1s	BP1	55
54	CP1s	DS2s	CD1	BP2s	A1s	BP1	54
53	CP1s	DS2s	CD1	BP2s	A1s	BP1	53
52	CP1s	DS2s	CD1	BP2s	A1s	BP1	52
51	CP1s	DS2s	CD1	BP2s	A1s	BP1	51
50	CP1s	DS2s	CD1	BP2s	A1s	BP1	50
49	CP1s	DS2s	CD1	BP2s	A1s	BP1	49
48	CP1s	DS2s	CD1	BP2s	A1s	BP1	48
47	CP1s	DS2s	CD1	BP2s	A1s	BP1	47
46	CP1s	DS2s	CD1	BP2s	A1s	BP1	46
45	CP1s	DS2s	CD1	BP2s	A1s	BP1	45
44	CP1s	DS2s	CD1	BP2s	A1s	BP1	44
43	ALTITUDE LOUNGE						43
42	CP1s	DP1	CD1	BP2s	A1s	BP1	42
41	CP1s	DP1	CD1	BP2s	A1s	BP1	41
40	CP1s	DP1	CD1	BP2s	A1s	BP1	40
39	CP1s	DP1	CD1	BP2s	A1s	BP1	39
38	CP1s	DP1	CD1	BP2s	A1s	BP1	38
37	CP1s	DP1	CD1	BP2s	A1s	BP1	37
36	CP1s	DP1	CD1	BP2s	A1s	BP1	36
35	CP1s	DP1	CD1	BP2s	A1s	BP1	35
34	CP1s	DP1	CD1	BP2s	A1s	BP1	34
33	CP1s	DP1	CD1	BP2s	A1s	BP1	33
32	CP1s	DP1	CD1	BP2s	A1s	BP1	32
31	CP1s	DP1	CD1	BP2s	A1s	BP1	31
30	CP1s	DP1	CD1	BP2s	A1s	BP1	30
29	CP1s	DP1	CD1	BP2s	A1s	BP1	29
28	CP1s	DP1	CD1	BP2s	A1s	BP1	28
27	CP1s	DP1	CD1	BP2s	A1s	BP1	27
26	CP1s	DP1	CD1	BP2s	A1s	BP1	26
25	CP1s	DP1	CD1	BP2s	A1s	BP1	25
24	CP1s	DP1	CD1	BP2s	A1s	BP1	24
23	CP1s	DP1	CD1	BP2s	A1s	BP1	23
22	HORIZON VISTA						22
21	CP1s	DP1	CD1	BP2s	A1s	BP1	21
20	CP1s	DP1	CD1	BP2s	A1s	BP1	20
19	CP1s	DP1	CD1	BP2s	A1s	BP1	19
18	CP1s	DP1	CD1	BP2s	A1s	BP1	18
17	CP1s	DP1	CD1	BP2s	A1s	BP1	17
16	CP1s	DP1	CD1	BP2s	A1s	BP1	16
15	CP1s	DP1	CD1	BP2s	A1s	BP1	15
14	CP1s	DP1	CD1	BP2s	A1s	BP1	14
13	CP1s	DP1	CD1	BP2s	A1s	BP1	13
12	CP1s	DP1	CD1	BP2s	A1s	BP1	12
11	CP1s	DP1	CD1	BP2s	A1s	BP1	11
10	CP1s	DP1	CD1	BP2s	A1s	BP1	10
9	CP1s	DP1	CD1	BP2s	A1s	BP1	9
8	CP1s	DP1	CD1	BP2s	A1s	BP1	8
7	CP1s	DP1	CD1	BP2s	A1s	BP1	7
6	CP1s	DP1	CD1	BP2s	A1s	BP1	6
5	CP1s	DP1	CD1	BP2s	A1s	BP1	5
4	CP1s	DP1	CD1	BP2s	A1s	BP1	4
3	CP1s	DP1	CD1	BP2s	A1s	BP1	3
2	CP1s	DP1	CD1	BP2s	A1s	BP1	2
1 <sup>ST</sup> / UPPER 1 <sup>ST</sup>	LANDSCAPE DECK						1 <sup>ST</sup> / UPPER 1 <sup>ST</sup>
B1 / LOWER 1 <sup>ST</sup>	EARLY CHILDHOOD DEVELOPMENT CENTRE   HAVELOCK MRT STATION						B1 / LOWER 1 <sup>ST</sup>
B2	RESIDENTIAL CARPARK						B2
B3	RESIDENTIAL CARPARK						B3

### LEGEND

- 1-Bedroom + Study
- 2-Bedroom
- 2-Bedroom Premium
- 2-Bedroom Premium + Study
- 3-Bedroom
- 3-Bedroom Deluxe
- 3-Bedroom Premium + Study
- 4-Bedroom Premium (with Private Lift)
- 4-Bedroom Supreme (with Private Lift)
- 4-Bedroom Supreme + Study (with Private Lift)
- 5-Bedroom Supreme (with Private Lift)
- Penthouse (5-Bedroom with Private Lift)

# 1-BEDROOM + STUDY

## TYPE A1s

44 sq m | 474 sq ft

### BLOCK 5

#02-11 to #21-11

#23-11 to #42-11

#44-11 to #62-11

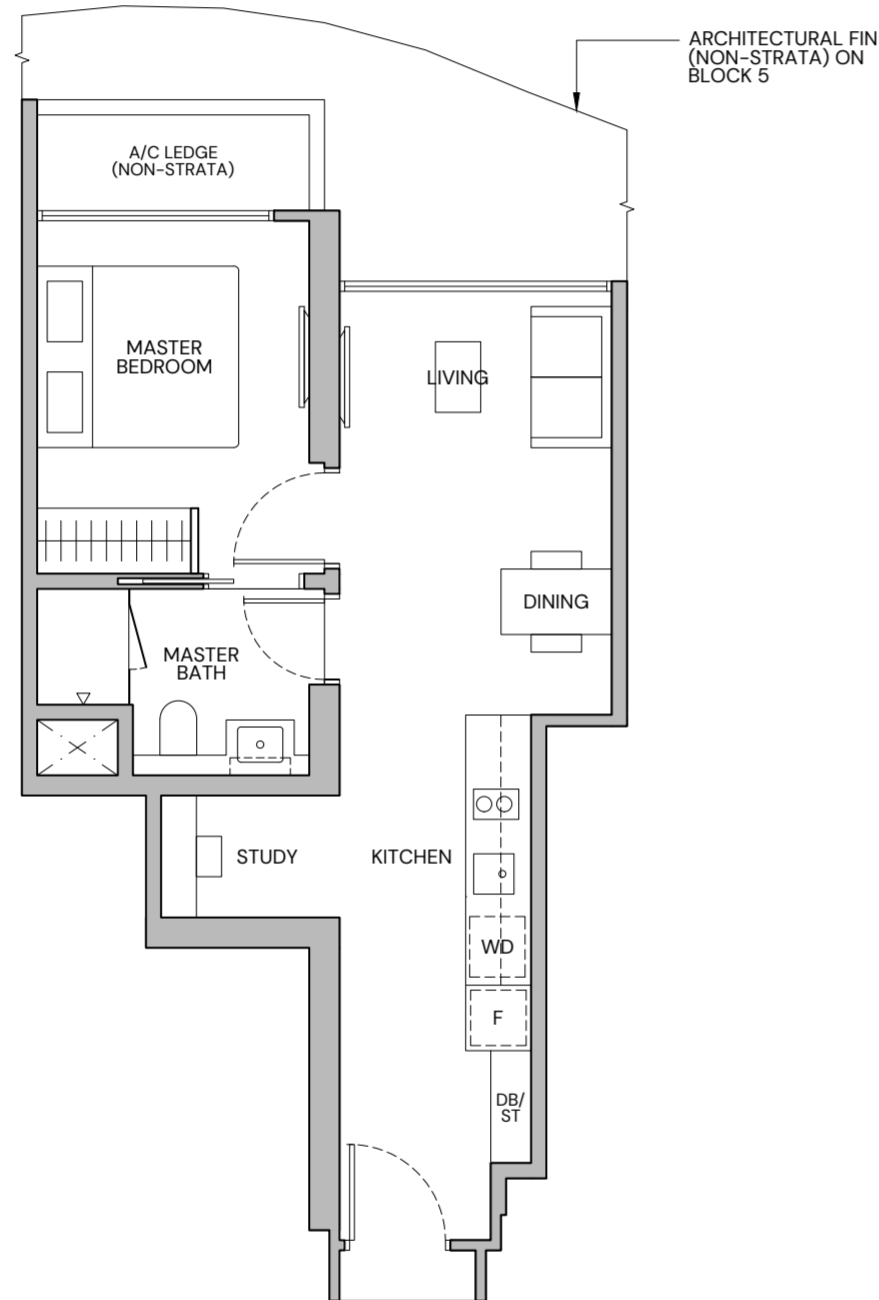

### LEGEND (WHERE APPLICABLE)

F	Fridge	HS	Household Shelter	CH	Wine Chiller	Wall not allowed to be hacked or altered
WD	Washer cum Dryer	DW	Dish Washer	WC	Water Closet	Services void space (excluded from strata area)
W/D	Washer and Dryer	DB/ST	Distribution Board/Storage	A/C	Air Conditioner	

Area includes balcony where applicable and excludes among others, the Architectural Fin, A/C - Air Conditioner Ledge, and Private Lift. The plans are subject to change as may be required by relevant authorities. All floor plans and areas are subject to final survey. The balcony shall not be enclosed unless with the approved balcony screen, more particularly illustrated under the header "Approved Balcony Screen". Please refer to the letter containing the Particulars, Documents and Information relating to the development and the unit, for the floor plan relating to the unit you intend to purchase. The Sale and Purchase Agreement contains the entire agreement between the developer and the purchaser and supercedes and cancels in all respects all previous representations, warranties, promises, inducements or statements of intention, whether written or oral made by the developer and/or the developer's agent which are not embodied in the Sale and Purchase Agreement.

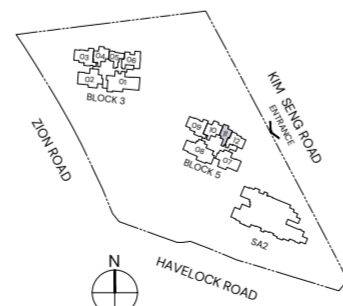

# 2-BEDROOM PREMIUM + STUDY

## TYPE BP2s

67 sq m | 721 sq ft

### BLOCK 3

#02-04 to #21-04

#23-04 to #42-04

#44-04 to #62-04

### BLOCK 5

#02-10 to #21-10

#23-10 to #42-10

#44-10 to #62-10

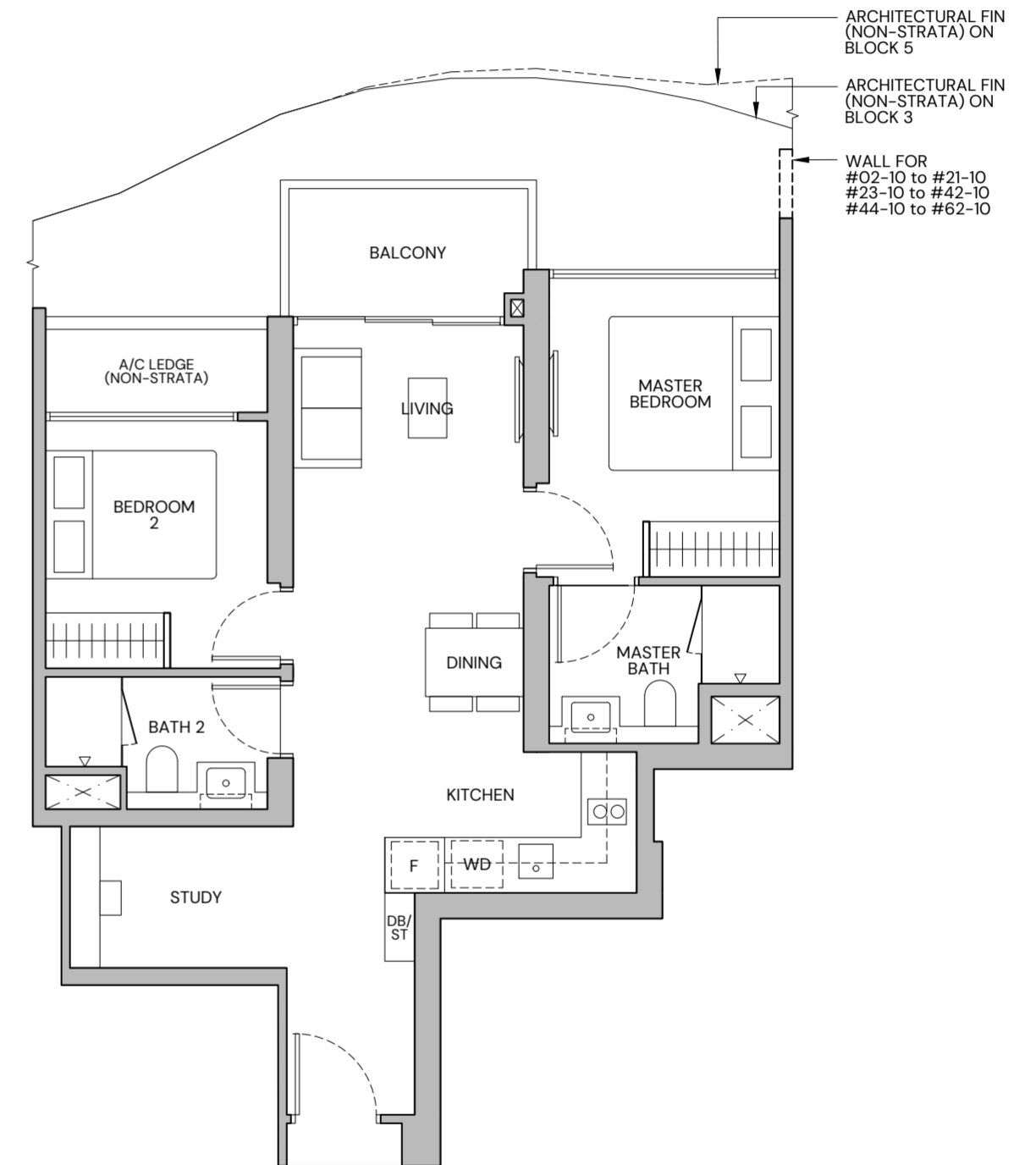

### LEGEND (WHERE APPLICABLE)

F	Fridge	HS	Household Shelter	CH	Wine Chiller	Wall not allowed to be hacked or altered
WD	Washer cum Dryer	DW	Dish Washer	WC	Water Closet	Services void space (excluded from strata area)
W/D	Washer and Dryer	DB/ST	Distribution Board/Storage	A/C	Air Conditioner	

Area includes balcony where applicable and excludes among others, the Architectural Fin, A/C - Air Conditioner Ledge, and Private Lift. The plans are subject to change as may be required by relevant authorities. All floor plans and areas are subject to final survey. The balcony shall not be enclosed unless with the approved balcony screen, more particularly illustrated under the header "Approved Balcony Screen". Please refer to the letter containing the Particulars, Documents and Information relating to the development and the unit, for the floor plan relating to the unit you intend to purchase. The Sale and Purchase Agreement contains the entire agreement between the developer and the purchaser and supercedes and cancels in all respects all previous representations, warranties, promises, inducements or statements of intention, whether written or oral made by the developer and/or the developer's agent which are not embodied in the Sale and Purchase Agreement.

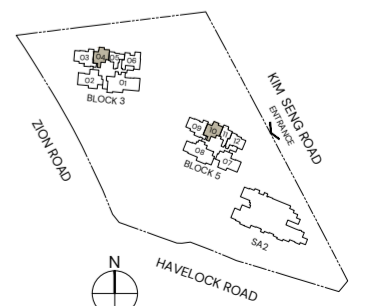

# 3-BEDROOM

TYPE C1

76 sq m | 818 sq ft

BLOCK 3

#02-06 to #21-06

#23-06 to #42-06

#44-06 to #62-06

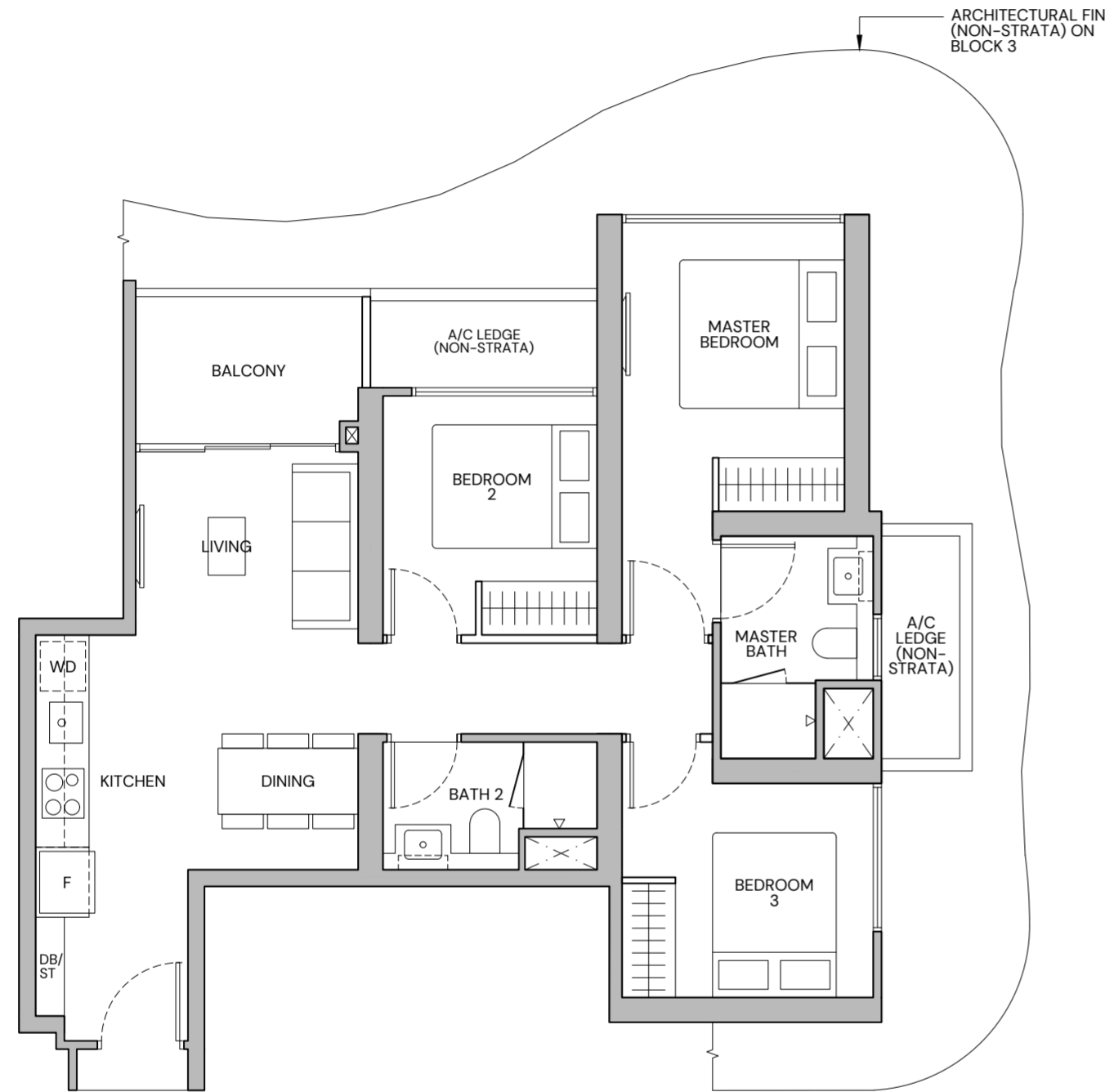

### LEGEND (WHERE APPLICABLE)

F	Fridge	HS	Household Shelter	CH	Wine Chiller	■	Wall not allowed to be hacked or altered
WD	Washer cum Dryer	DW	Dish Washer	WC	Water Closet	⊠	Services void space (excluded from strata area)
W/D	Washer and Dryer	DB/ST	Distribution Board/Storage	A/C	Air Conditioner		

Area includes balcony where applicable and excludes among others, the Architectural Fin, A/C - Air Conditioner Ledge, and Private Lift. The plans are subject to change as may be required by relevant authorities. All floor plans and areas are subject to final survey. The balcony shall not be enclosed unless with the approved balcony screen, more particularly illustrated under the header "Approved Balcony Screen". Please refer to the letter containing the Particulars, Documents and Information relating to the development and the unit, for the floor plan relating to the unit you intend to purchase. The Sale and Purchase Agreement contains the entire agreement between the developer and the purchaser and supersedes and cancels in all respects all previous representations, warranties, promises, inducements or statements of intention, whether written or oral made by the developer and/or the developer's agent which are not embodied in the Sale and Purchase Agreement.

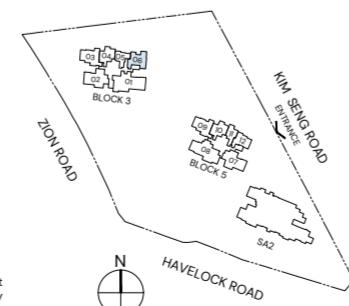

Key Plan is not drawn to scale

# 3-BEDROOM DELUXE

TYPE CD1

80 sq m | 861 sq ft

BLOCK 3

#02-03 to #21-03

#23-03 to #42-03

#44-03 to #62-03

BLOCK 5

#02-09 to #21-09

#23-09 to #42-09

#44-09 to #62-09

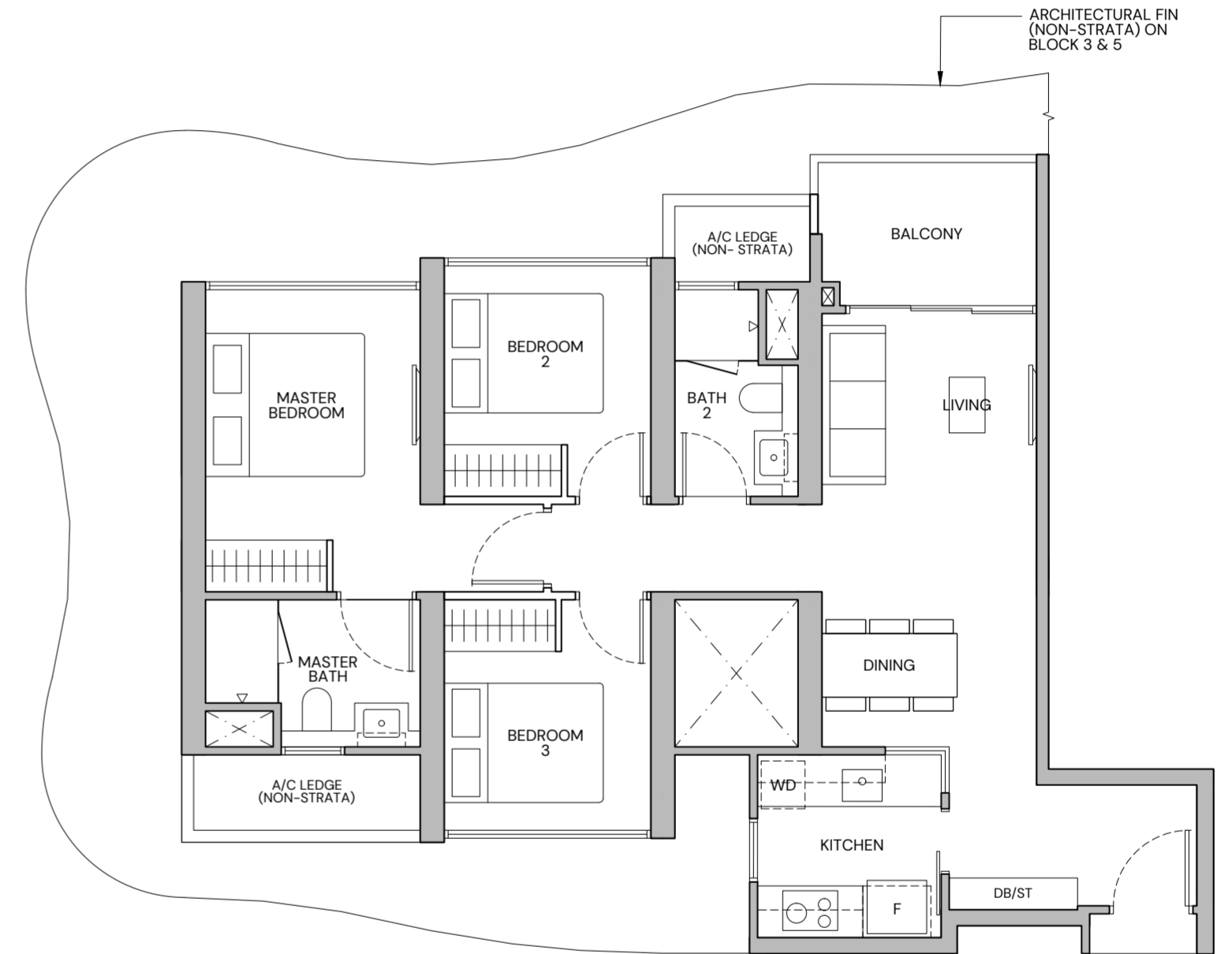

### LEGEND (WHERE APPLICABLE)

F	Fridge	HS	Household Shelter	CH	Wine Chiller	■	Wall not allowed to be hacked or altered
WD	Washer cum Dryer	DW	Dish Washer	WC	Water Closet	⊠	Services void space (excluded from strata area)
W/D	Washer and Dryer	DB/ST	Distribution Board/Storage	A/C	Air Conditioner		

Area includes balcony where applicable and excludes among others, the Architectural Fin, A/C - Air Conditioner Ledge, and Private Lift. The plans are subject to change as may be required by relevant authorities. All floor plans and areas are subject to final survey. The balcony shall not be enclosed unless with the approved balcony screen, more particularly illustrated under the header "Approved Balcony Screen". Please refer to the letter containing the Particulars, Documents and Information relating to the development and the unit, for the floor plan relating to the unit you intend to purchase. The Sale and Purchase Agreement contains the entire agreement between the developer and the purchaser and supersedes and cancels in all respects all previous representations, warranties, promises, inducements or statements of intention, whether written or oral made by the developer and/or the developer's agent which are not embodied in the Sale and Purchase Agreement.

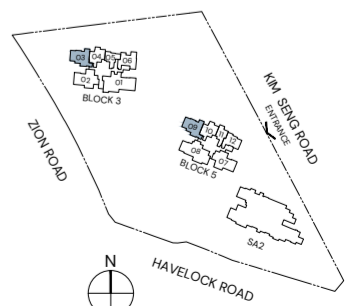

Key Plan is not drawn to scale

# 4-BEDROOM PREMIUM (WITH PRIVATE LIFT)

**TYPE DPI**  
132 sq m | 1421 sq ft

BLOCK 5  
#02-08 to #21-08  
#23-08 to #42-08

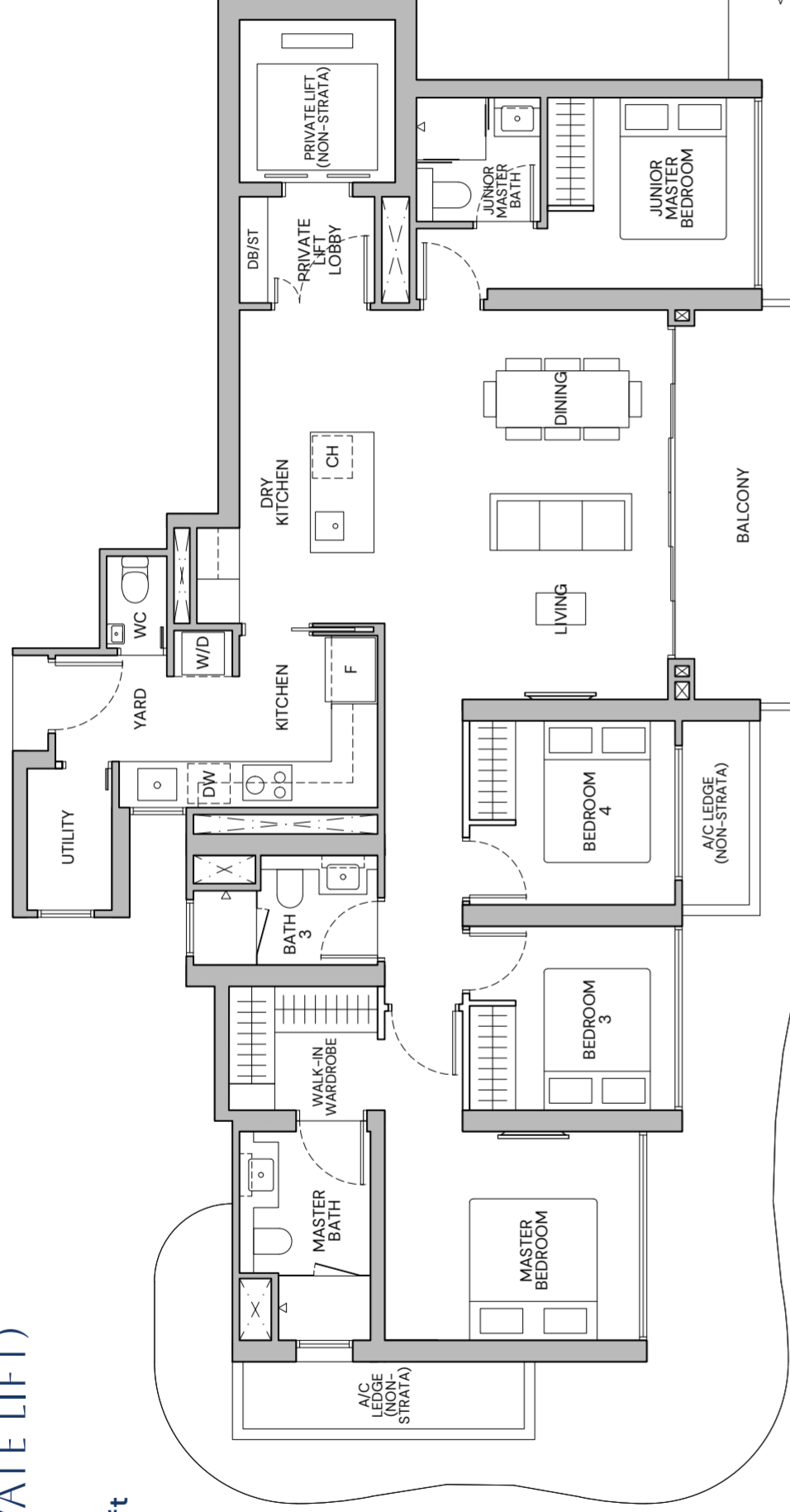

Key Plan is not drawn to scale



**LEGEND (WHERE APPLICABLE)**

- F Fridge
- DW Dish Washer
- WD Washer cum Dryer
- W/D Washer and Dryer
- CH Wine Chiller
- WC Water Closet
- DB/ST Distribution Board/Storage
- A/C Air Conditioner
- HS Household Shelter
- ▬ Wall not allowed to be hacked or altered
- ⊠ Services void space (excluded from strata area)

Area includes balcony where applicable and excludes among others, the Architectural Fin, A/C - Air Conditioner Ledge, and Private Lift. The plans are subject to change as may be required by relevant authorities. All floor plans and areas are subject to final survey. The balcony shall not be enclosed unless with the approved balcony screen, more particularly illustrated under the header "Approved Balcony Screen". Please refer to the letter containing the Particulars, Documents and Information relating to the development and the unit, for the floor plan relating to the unit you intend to purchase. The Sale and Purchase Agreement contains the entire agreement between the developer and the purchaser and supersedes all in all respects all previous representations, warranties, promises, inducements or statements of intention, whether written or oral made by the developer and/or the developer's agent which are not embodied in the Sale and Purchase Agreement.

# 4-BEDROOM SUPREME (WITH PRIVATE LIFT)

**TYPE DSI**  
141 sq m | 1518 sq ft

BLOCK 3  
#02-01 to #21-01  
#23-01 to #42-01

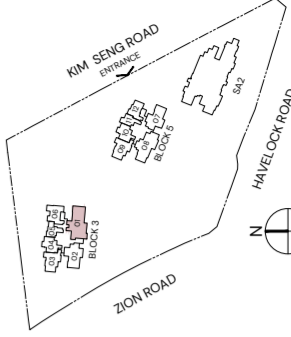
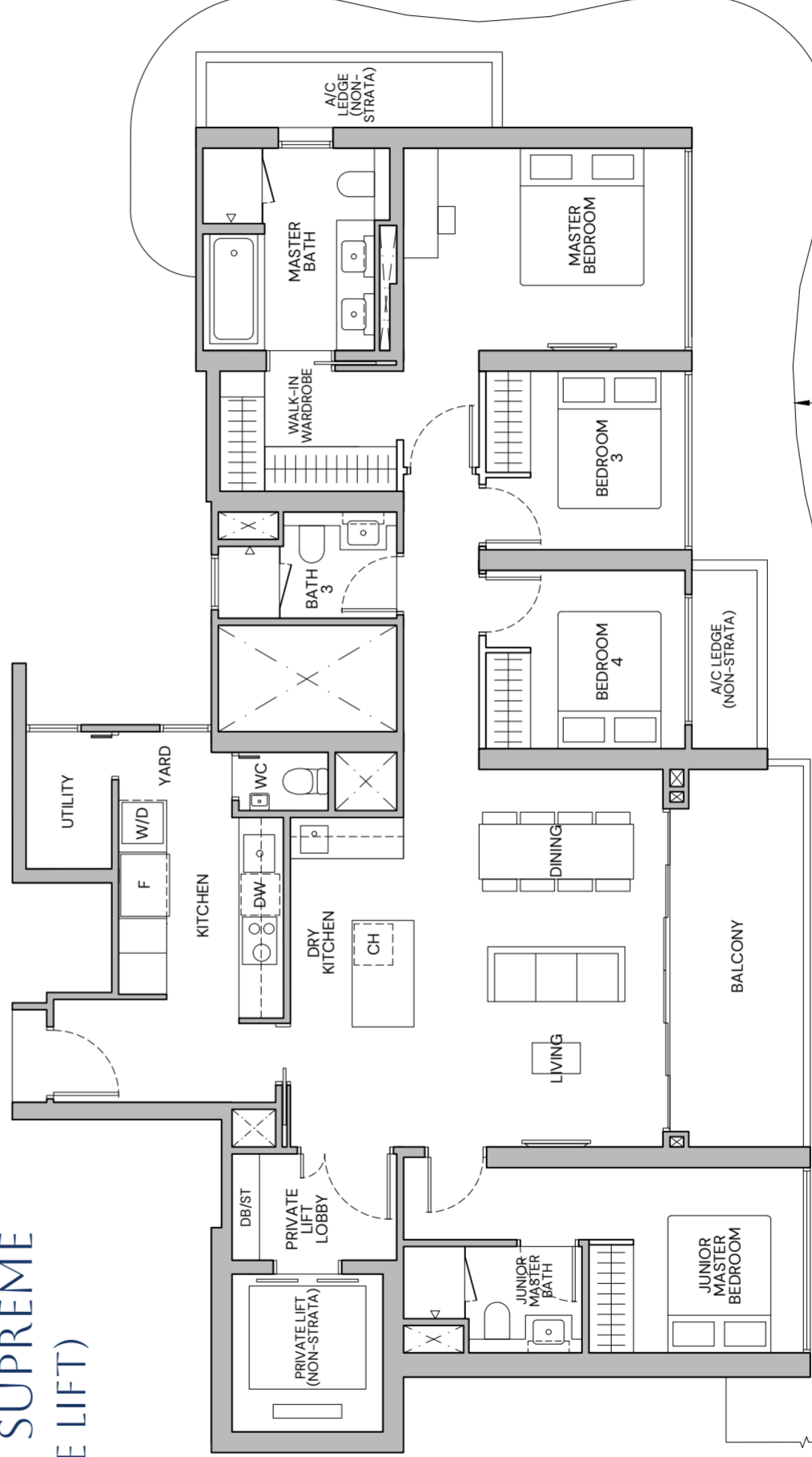

Key Plan is not drawn to scale



**LEGEND (WHERE APPLICABLE)**

- F Fridge
- DW Dish Washer
- WD Washer cum Dryer
- W/D Washer and Dryer
- CH Wine Chiller
- WC Water Closet
- DB/ST Distribution Board/Storage
- A/C Air Conditioner
- HS Household Shelter
- ▬ Wall not allowed to be hacked or altered
- ⊠ Services void space (excluded from strata area)

Area includes balcony where applicable and excludes among others, the Architectural Fin, A/C - Air Conditioner Ledge, and Private Lift. The plans are subject to change as may be required by relevant authorities. All floor plans and areas are subject to final survey. The balcony shall not be enclosed unless with the approved balcony screen, more particularly illustrated under the header "Approved Balcony Screen". Please refer to the letter containing the Particulars, Documents and Information relating to the development and the unit, for the floor plan relating to the unit you intend to purchase. The Sale and Purchase Agreement contains the entire agreement between the developer and the purchaser and supersedes all in all respects all previous representations, warranties, promises, inducements or statements of intention, whether written or oral made by the developer and/or the developer's agent which are not embodied in the Sale and Purchase Agreement.

# 4-BEDROOM SUPREME + STUDY (WITH PRIVATE LIFT)

**TYPE DS2s**  
150 sq m | 1615 sq ft

BLOCK 5  
#44-08 to #61-08

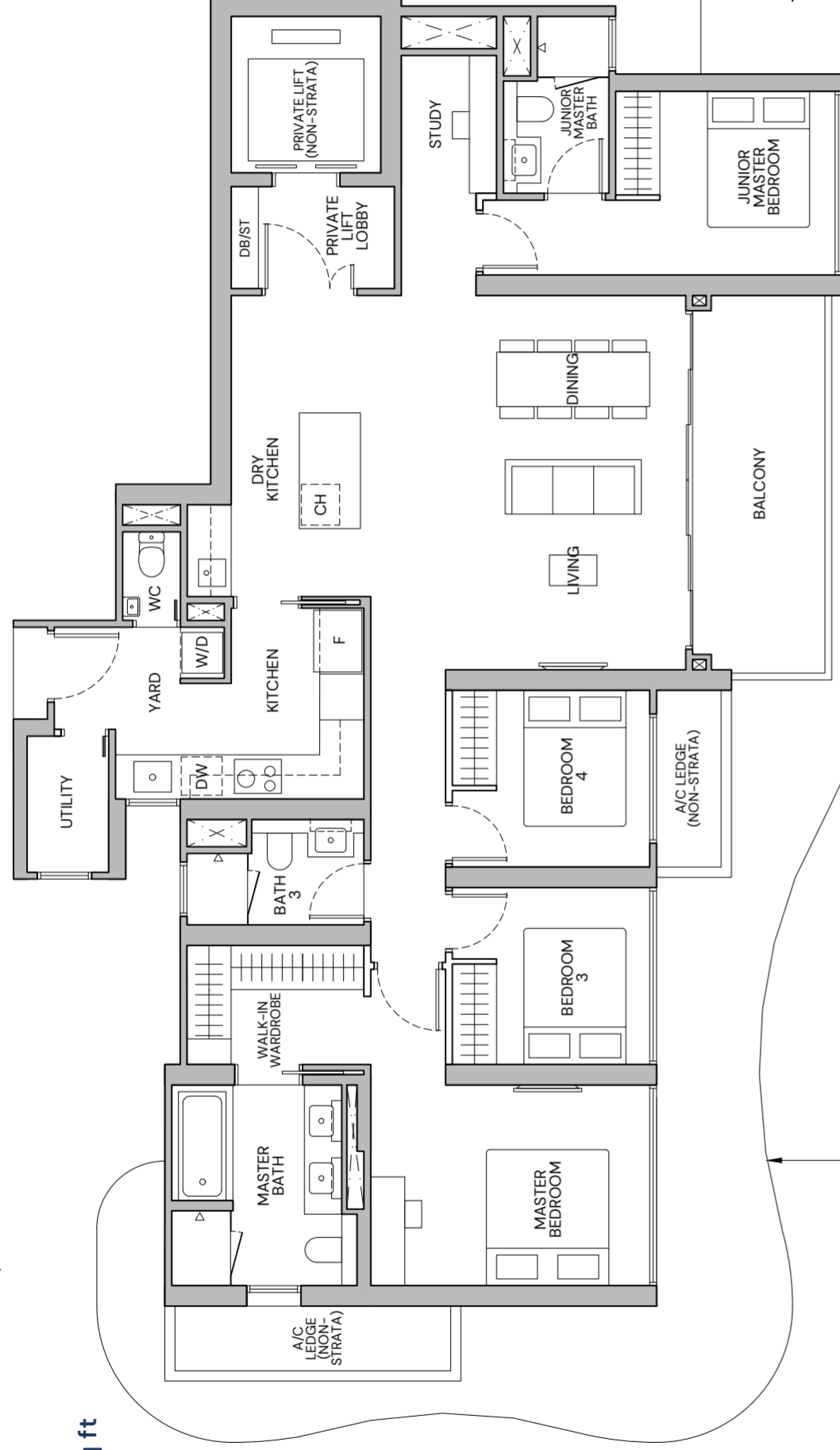

ARCHITECTURAL FIN  
(NON-STRATA) ON  
BLOCK 5

### LEGEND (WHERE APPLICABLE)

- F Fridge
- WD Washer cum Dryer
- CH Wine Chiller
- WC Water Closet
- DB/ST Distribution Board/Storage
- A/C Air Conditioner
- HS Household Shelter
- DW Dish Washer
- W/D Washer and Dryer
- WC WC
- Services void space (excluded from strata area)

Area includes balcony where applicable and excludes among others, the Architectural Fin, A/C - Air Conditioner Ledge, and Private Lift. The plans are subject to change as may be required by relevant authorities. All floor plans and areas are subject to final survey. The balcony shall not be enclosed unless with the approved balcony screen, more particularly illustrated under the header "Approved Balcony Screen". Please refer to the letter containing the Particulars, Documents and Information relating to the development and the unit, for the floor plan relating to the unit you intend to purchase. The Sale and Purchase Agreement contains the entire agreement between the developer and the purchaser and supersedes and cancels in all respects all previous representations, warranties, promises, inducements or statements of intention, whether written or oral made by the developer and/or the developer's agent which are not embodied in the Sale and Purchase Agreement.

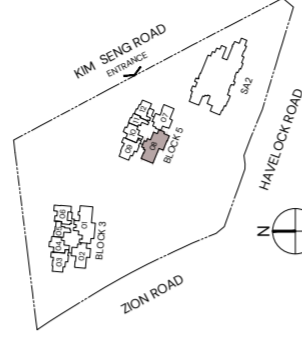

Key Plan is not drawn to scale

# 5-BEDROOM SUPREME (WITH PRIVATE LIFT)

**TYPE ES1**  
169 sq m | 1819 sq ft

BLOCK 3  
#44-01 to #61-01

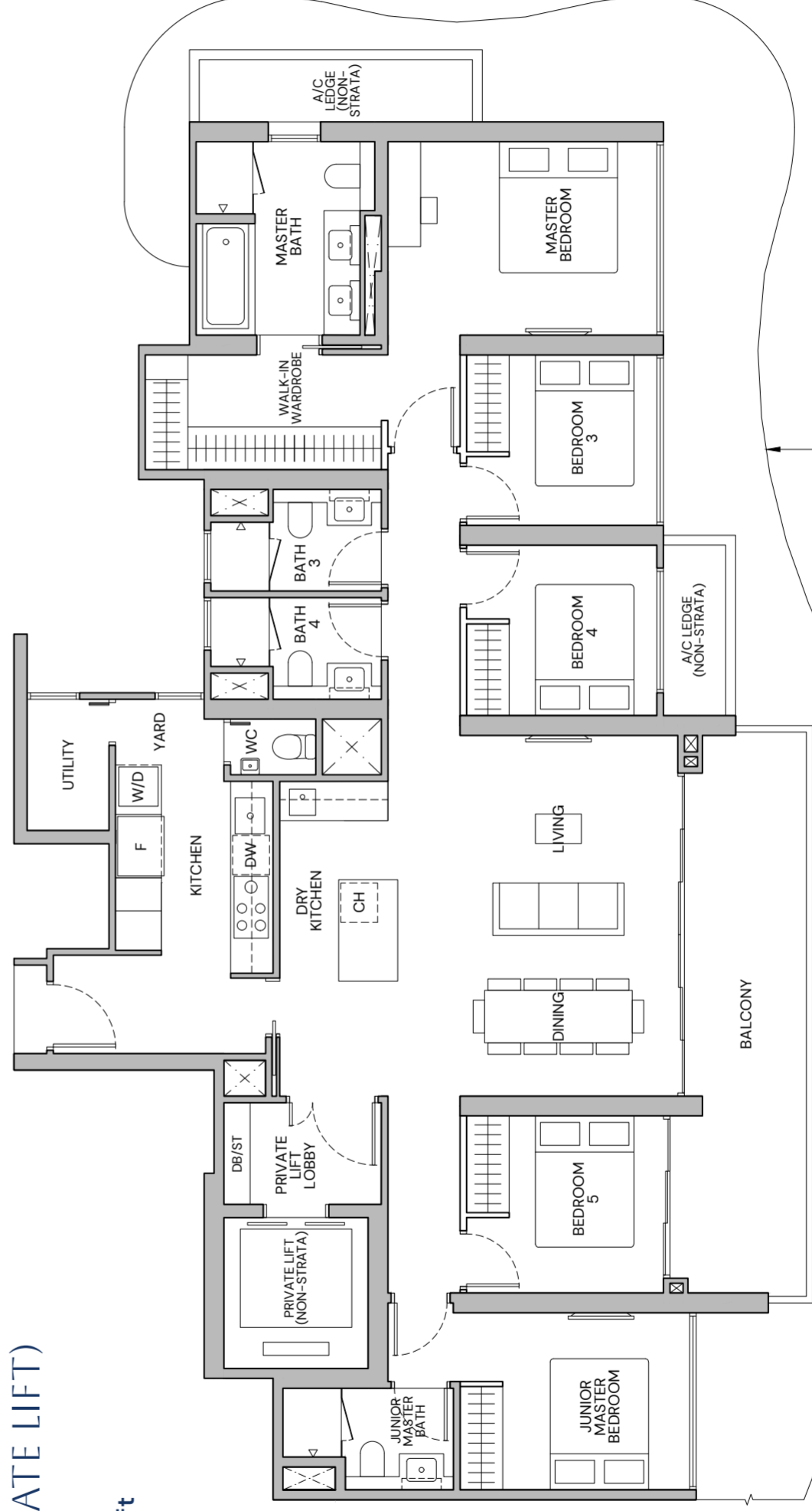

ARCHITECTURAL FIN  
(NON-STRATA) ON  
BLOCK 3

### LEGEND (WHERE APPLICABLE)

- F Fridge
- WD Washer cum Dryer
- CH Wine Chiller
- WC Water Closet
- DB/ST Distribution Board/Storage
- A/C Air Conditioner
- HS Household Shelter
- DW Dish Washer
- W/D Washer and Dryer
- WC WC
- Services void space (excluded from strata area)

Area includes balcony where applicable and excludes among others, the Architectural Fin, A/C - Air Conditioner Ledge, and Private Lift. The plans are subject to change as may be required by relevant authorities. All floor plans and areas are subject to final survey. The balcony shall not be enclosed unless with the approved balcony screen, more particularly illustrated under the header "Approved Balcony Screen". Please refer to the letter containing the Particulars, Documents and Information relating to the development and the unit, for the floor plan relating to the unit you intend to purchase. The Sale and Purchase Agreement contains the entire agreement between the developer and the purchaser and supersedes and cancels in all respects all previous representations, warranties, promises, inducements or statements of intention, whether written or oral made by the developer and/or the developer's agent which are not embodied in the Sale and Purchase Agreement.

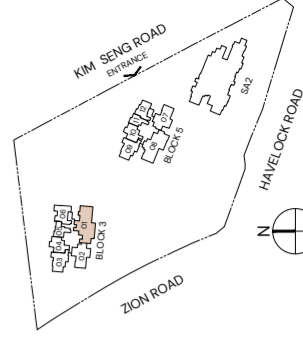

Key Plan is not drawn to scale

EXCLUSIVE PENTHOUSES

## OWN THE SKY AND YOUR WORLD AROUND

Crowning the towers, two exclusive 5-Bedroom Penthouses on Level 62 offer an exceptional sense of privacy and space, each served by a private lift. From this rare vantage point – among the tallest residences in the city – spectacular panoramic views unfold from your home.



Within these impeccable penthouses, beautiful marble flooring lends grandeur and gravitas to the living and dining areas, while warm timber tones in the bedrooms create spaces of sublime tranquillity. With expansive interiors and commanding views, these rare penthouses are envisioned for a life lived above and beyond.



Luxurious master bedroom with refined sophistication



Expansive living and dining areas with breathtaking skyline vistas

# PENTHOUSE

## (5-BEDROOM WITH PRIVATE LIFT)

TYPE PH2  
256 sq m | 2756 sq ft

BLOCK 3  
#62-01

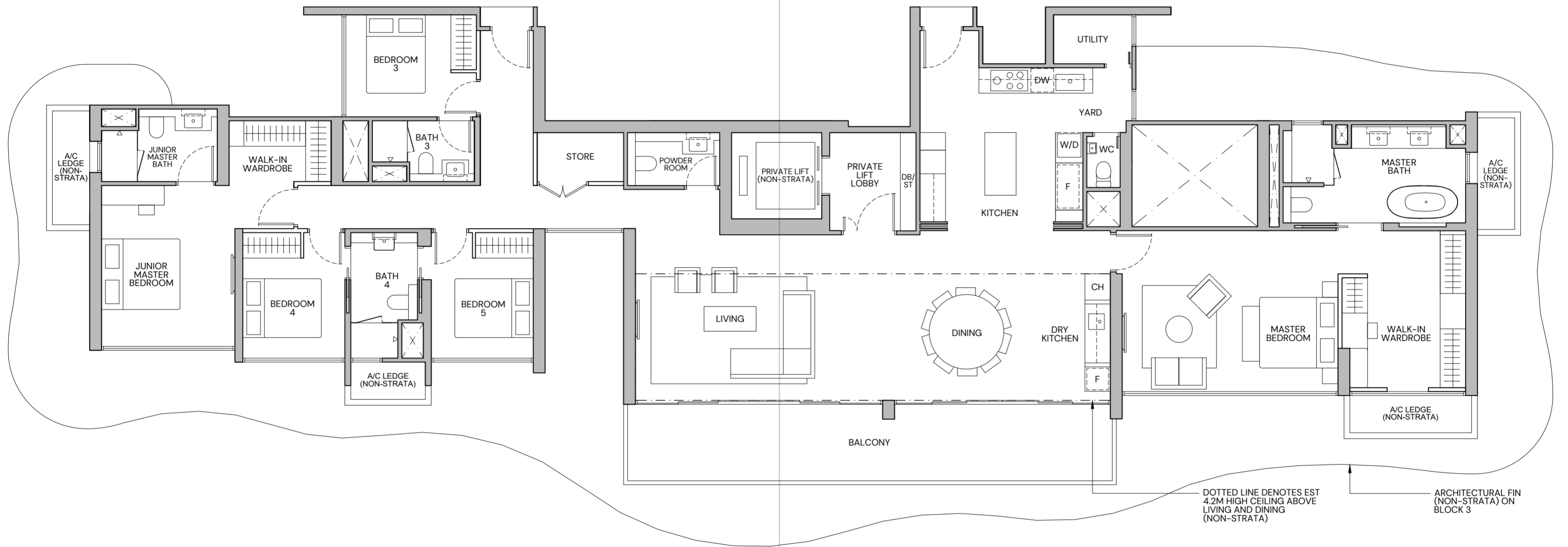

DOTTED LINE DENOTES EST  
4.2M HIGH CEILING ABOVE  
LIVING AND DINING  
(NON-STRATA)

ARCHITECTURAL FIN  
(NON-STRATA) ON  
BLOCK 3

0 1 2 3 4 5M

### LEGEND (WHERE APPLICABLE)

F	Fridge	DW	Dish Washer	CH	Wine Chiller	DB/ST	Distribution Board/Storage	HS	Household Shelter
WD	Washer cum Dryer	W/D	Washer and Dryer	WC	Water Closet	A/C	Air Conditioner		
▬	Wall not allowed to be hacked or altered	⊠	Services void space (excluded from strata area)						

Area includes balcony where applicable and excludes among others, the Architectural Fin, A/C - Air Conditioner Ledge, and Private Lift. The plans are subject to change as may be required by relevant authorities. All floor plans and areas are subject to final survey. The balcony shall not be enclosed unless with the approved balcony screen, more particularly illustrated under the header "Approved Balcony Screen". Please refer to the letter containing the Particulars, Documents and Information relating to the development and the unit, for the floor plan relating to the unit you intend to purchase. The Sale and Purchase Agreement contains the entire agreement between the developer and the purchaser and supersedes and cancels in all respects all previous representations, warranties, promises, inducements or statements of intention, whether written or oral made by the developer and/or the developer's agent which are not embodied in the Sale and Purchase Agreement.

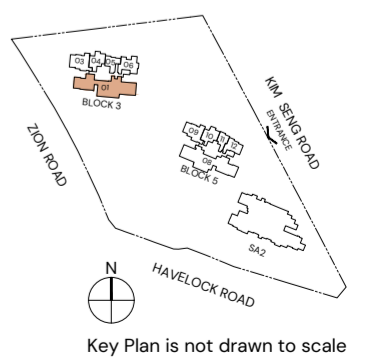

Key Plan is not drawn to scale

# APPROVED BALCONY SCREEN

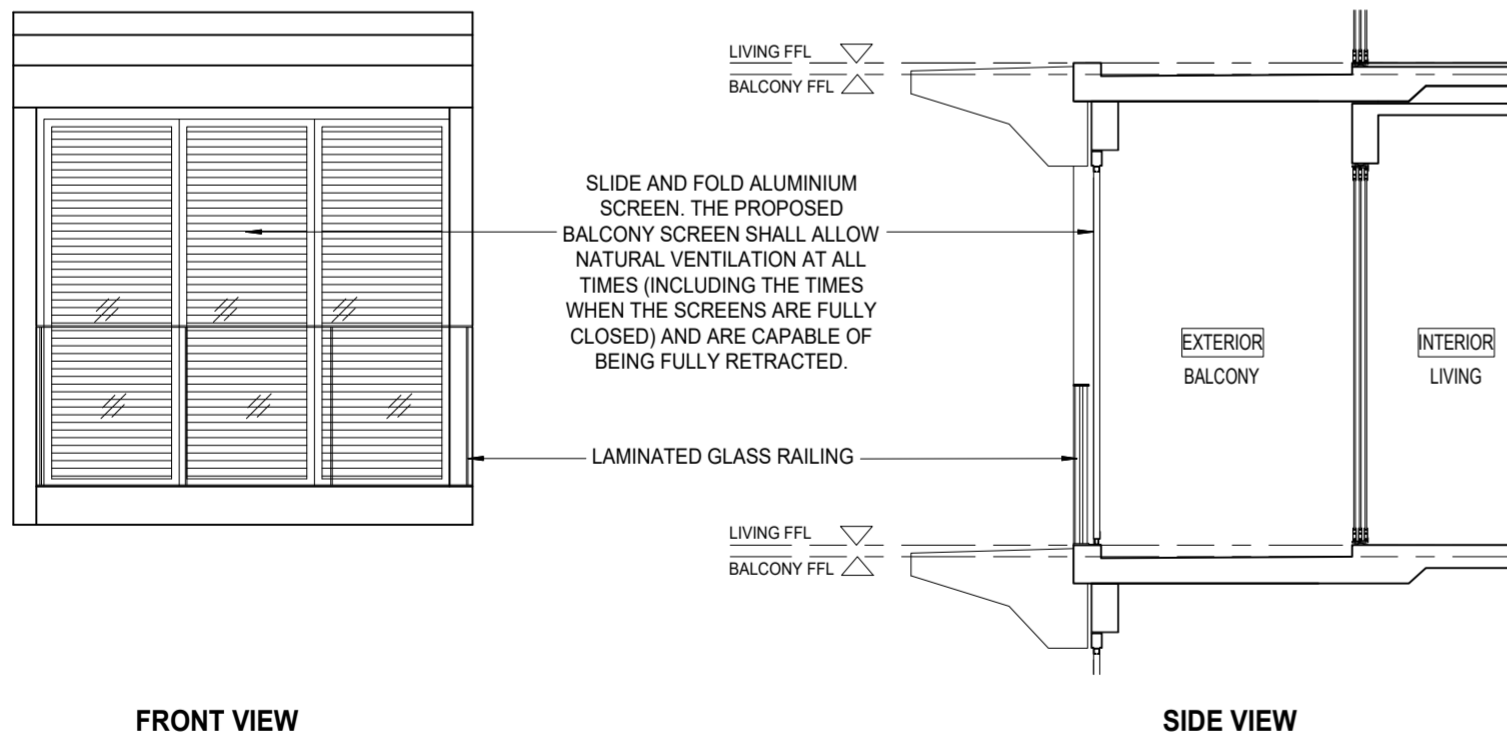
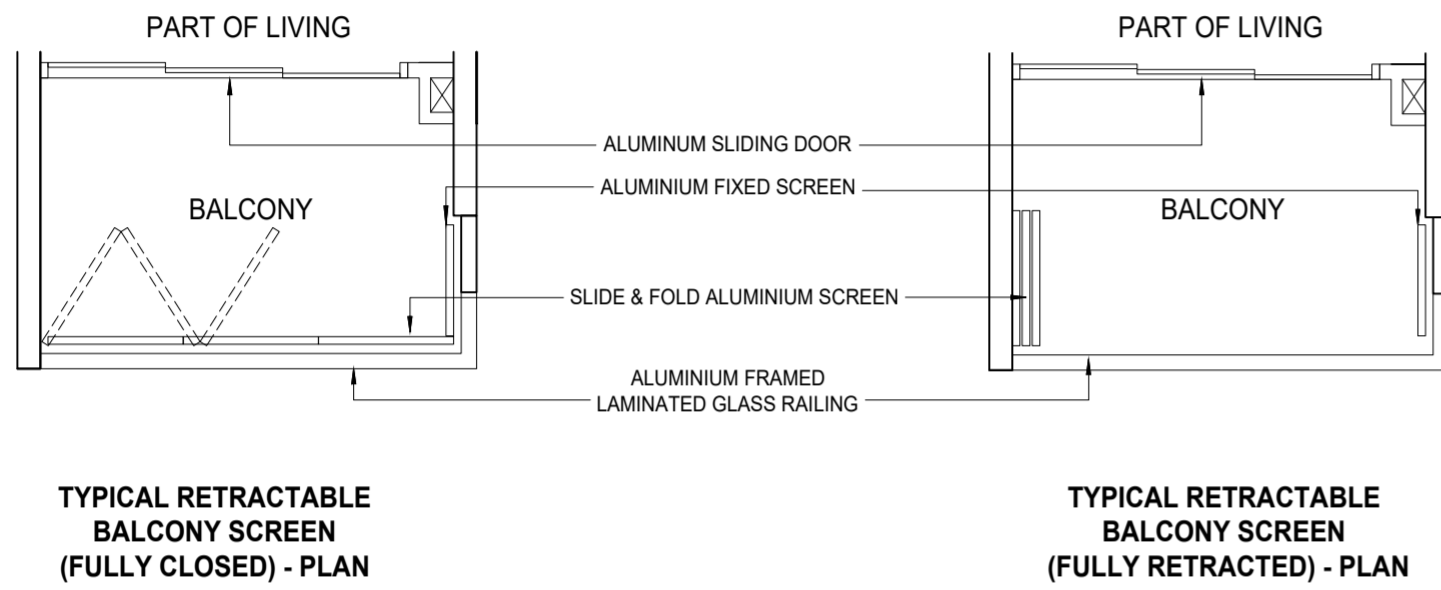

**NOTE**  
 The balcony shall not be enclosed unless with the approved balcony screen as shown above.  
 The cost of screen and installation shall be borne by the Purchaser.  
 Where required to facilitate installation, the Architect reserves the right to determine appropriate details not limited to fixing details and colour tones.

THOSE WHO SET THE STANDARD  
RESERVE THE RIGHT TO RAISE IT

# 146 YEARS OF COMBINED EXPERIENCE CREATING WORLD-CLASS HOMES



## SINGAPORE'S TRUSTED PROPERTY PIONEER SINCE 1963

City Developments Limited (CDL) is a leading global real estate company with a network spanning 168 locations in 29 countries and regions. Listed on the Singapore Exchange, the Group is one of the largest companies by market capitalisation. Its income-stable and geographically diverse portfolio comprises residences, offices, hotels, serviced apartments, student accommodation, retail malls and integrated developments.

With a proven track record of over 60 years in real estate development, investment and management, the Group has developed over 53,000 homes and owns around 23 million square feet of gross floor area in residential for lease, commercial and hospitality assets globally.

The Group owns, operates or manages over 160 hotels worldwide, many in key gateway cities, primarily through its flagship Millennium Hotels and Resorts, Singapore's largest homegrown hotel operator, featuring brands like The Biltmore, Grand Millennium, Millennium, M Social, Copthorne and Kingsgate.



GRAMERCY PARK



IRWELL HILL RESIDENCES



NEW FUTURA



Mitsui Fudosan has its origins in Echigo-ya, a clothing store opened in 1673 in what is now the Nihonbashi district of Tokyo. In 1941, the real estate division of Mitsui Company was separated from the parent company and Mitsui Fudosan Co., Ltd. was established.

Today, Mitsui Fudosan Group is Japan's largest real estate developer with a history of innovation that has kept it at the forefront of the real estate industry. Throughout the years, Mitsui Fudosan was responsible for the sponsorship of Japan's first REIT, the development of Japan's first factory outlet, Japan's first regional shopping mall, and first office skyscraper.

As an all-rounded property industry player, Mitsui Fudosan Group is providing solutions and services in a wide range of business areas, including office buildings, commercial facilities, hotels and resorts, logistics, and housing. About Mitsui Fudosan Group's Overseas Strategy, the group has been operating in major cities in North America, Europe, China, Taiwan, Southeast Asia, India, and Australia. Mitsui Fudosan's long-term plan, "8 INNOVATION 2030" formulated in April 2024, aims to achieve robust growth in overseas business.



PARK COURT AOYAMA  
THE TOWER

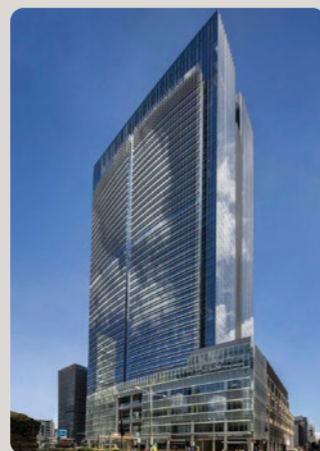

TOKYO MIDTOWN YAESU



50 HUDSON YARDS

FOR THE PRIVILEGE  
OF OWNERSHIP  
(65) 6877 1818

Scan to view  
specifications



Developer / Vendor: CDL-MFA Altair Property Pte. Ltd. (UEN No: 202413177K) and CDL-MFA Vega Property Pte. Ltd. (UEN No.: 202413192C) • Tenure of Land: Leasehold 99 years commencing from 15 July 2024 • Lot No.: Lot 02478W TS24 at Zion Road • Housing Developer's Licence No.: C1515 • Encumbrances: Caveat IJ/587564D in favour of CIMB Bank Berhad • Expected Date of Vacant Possession: 30 Sep 2032 • Expected Date of Legal Completion: 30 Sep 2035

Residential Services: Please note that the use of these services and facilities are chargeable as they are provided by third party service providers ("Service Providers"). While our Residential Host will assist in making arrangements, all costs incurred for use of these services and facilities are to be borne by residents. Provision of these services and facilities may be modified according to availability and at the discretion of the Service Providers. The Service Providers also reserve the right to terminate the services and facilities without prior notice. Other terms and conditions apply. Visual representations are not representations of the actual provision.

While reasonable care has been taken in the preparation of this brochure, neither the developer nor its agents assume any responsibility for any inaccuracies or omissions. The statements, information and depictions in this brochure are not to be relied upon as statements or representations of fact, offers or warranties (whether expressly or impliedly) by the developer or the developer's agents and they are not intended to form any part of the contract for the sale of the housing units. Visual representations such as renderings, illustrations, pictures and drawings are artists' impressions only and photographs are only decor suggestions and cannot be regarded as representations of fact. The brand, colour and model of all materials, fittings, equipment, finishes, installations and appliances to be supplied shall be provided subject to the developer's architect's selection, market availability and at the sole discretion of the developer. All information and specifications contained in this brochure are subject to such changes as are required by the relevant authorities or the developer. All plans are subject to any amendments which are required by the relevant authorities. All areas and measurements stated in the brochure are approximate only and subject to final survey. The Sale and Purchase Agreement contains the entire agreement between the developer and the purchaser and supersedes and cancels in all respects all previous representations, warranties, promises, inducements or statements of intention, whether written or oral made by the developer and/or the developer's agent which are not embodied in the Sale and Purchase Agreement.

This brochure is printed on eco-friendly paper, Oct 2025.

